



FUNDICIÓ DÚCTIL BENITO
Tel. 93 852 10 00

Zar

DESIGNER:

MANUFACTURER: Fundicio Ductil Benito

DIMENSIONS: mm

SCALE: 1/20

UM389

REFERENCE

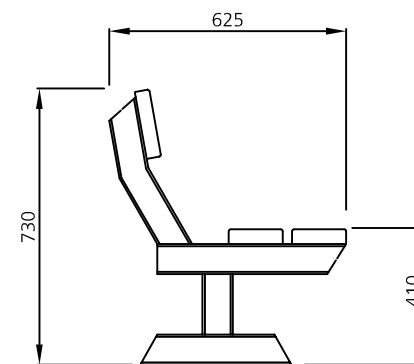
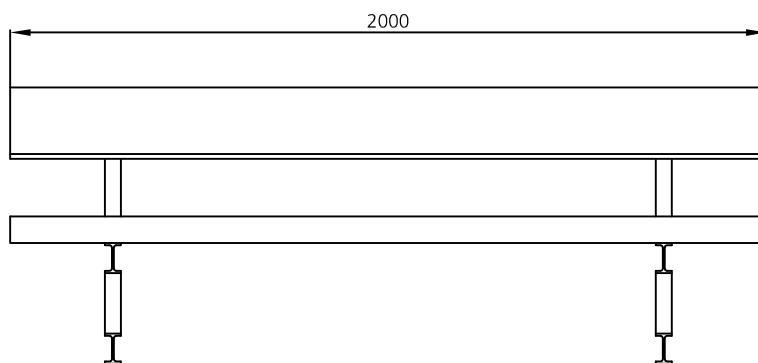

- MATERIAL:** Ductile iron legs. 5 tropical wooden boards of 140x70 mm section for the seat and one more board of 200x45mm section for the backrest. Stainless steel screws.
- FINISH:** Legs with a primed coat and two more coats of black forge oxiron. Tropical wood treated with "Lignus", a preventive fungicide, insecticide and water proofed product. Mahogany colour finish.
- RECOMMENDED ANCHORAGE:** M10 fixing bolts for anchoring to the ground, depending on the surface and the project.



FUNDICIÓ DÚCTIL BENITO
Tel. 93 852 10 00

ANCHORAGE DETAIL

DESIGNER:

MANUFACTURER:

DIMENSIONS: mm

SCALE:

REFERENCE

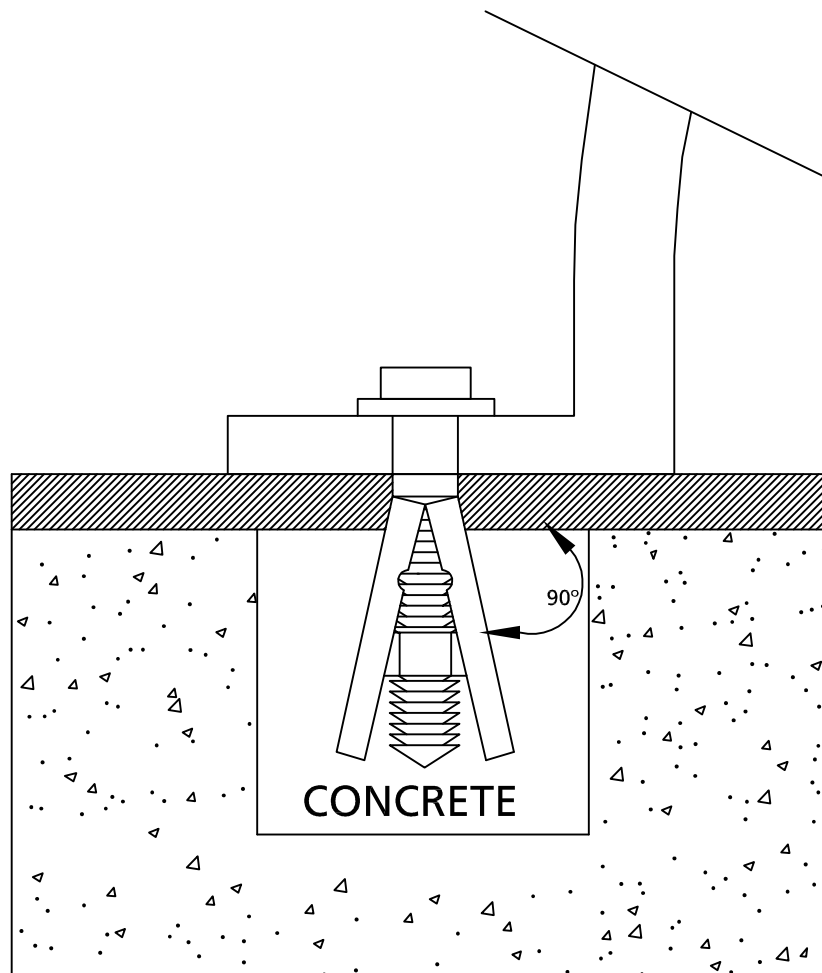

Fundicio Ductil Benito involved with her continous improvement line of her products, reserves the right to modify measures, materials and or finishings without prior notice.